

Three-phase dv/dt-reactor for efficient motor protection

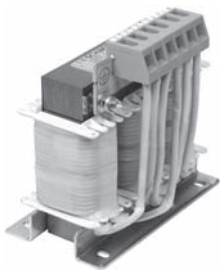

- Reduction of drive output voltage dv/dt
- Reduction of motor temperature
- Increase of motor service life
- Compact and economic open frame design
- Standard catalog reactors up to 2300A
- UL-rated materials used

Approvals

RoHS
2002/95/EC
By January 2006

Technical specifications

Maximum continuous operating voltage:	3x 500VAC
Motor frequency:	max. 60Hz
Switching frequency:	2 to 16kHz
Rated currents:	2.1 to 2300A @ 40°C
Motor cable length:	max. 30m @ 16kHz (derating curve next page)
Impedance (uk):	0.8% @ 400VAC, 50Hz & rated current
Typical dv/dt reduction:	≥ factor 5
High potential test voltage:	P → E 3000VAC for 3 sec P → P 3000VAC for 3 sec
Protection category:	IP00 (KL-types according to VBG4)
Overload capability:	2x rated current at switch on for 30 seconds 1.5x rated current for 1 minute, once per hour
Temperature range (operation and storage):	-25°C to +100°C (25/100/21)
Insulation class:	T40/B (130°C) → RWK 305 ≤ 110A T40/F (155°C) → RWK 305 > 110A
Flammability corresponding to:	UL94V-2 or better
Design corresponding to:	EN61558-2-20 (VDE0570-2-20)
MTBF @ 40°C/400V (Mil-HB-217F):	>200,000 hours

Typical electrical schematic

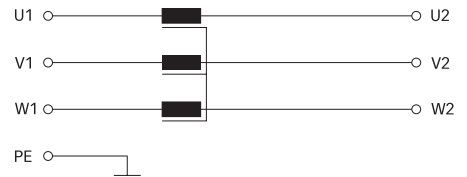



Features and benefits

- Efficient reduction of high output voltage dv/dt from IGBT motor drives.
- Protection of motor coil insulation from premature aging and destruction.
- Significantly increased service life of electric motors.
- High reliability and secured production up-time for mission critical applications.
- Reduced converter pulse load.
- Less interference propagation towards neighbouring equipment or lines.
- „Output filter“ with low impedance, ideal for processes requiring exceptional precision and reproducibility of movements.
- Vacuum impregnation for reduced humming noise and high durability.

Typical applications

- Servo drives
- Close loop vector drives
- Motor drive applications with short motor cables
- Machinery comprising servo or torque motors
- Robots
- Pick and place machines

Reactor selection table

Reactor	Rated current @ 40°C [A]	Typical motor power rating* [kW]	Nominal inductance [mH]	Typical power loss** [W]	Input/Output connections			Total [kg]	Cu. [kg]	Weight Al. [kg]
										
RWK 305-2.1-KL	2.1	0.75	2.8	20	KL			1.2	0.1	
RWK 305-4-KL	4	1.5	1.47	22	KL			1.2	0.14	
RWK 305-7.8-KL	7.8	3	0.754	25	KL			1.2	0.28	
RWK 305-10-KL	10	4	0.588	30	KL			1.8	0.22	
RWK 305-14-KL	14	5.5	0.42	34	KL			2.2	0.35	
RWK 305-17-KL	17	7.5	0.346	38	KL			2.5	0.5	
RWK 305-24-KL	24	11	0.245	45	KL			2.5	0.5	
RWK 305-32-KL	32	15	0.184	55	KL			3.9	0.56	
RWK 305-45-KL	45	22	0.131	60	KL			6.1	0.7	
RWK 305-60-KL	60	30	0.098	65	KL			6.1	1.3	
RWK 305-72-KL	72	37	0.082	70	KL			6.1	1.6	
RWK 305-90-KL	90	45	0.065	75	KL			7.4	2.4	
RWK 305-110-KL	110	55	0.053	90	KL			8.2	2.4	
RWK 305-124-KS	124	55	0.047	110		KS		8.2	2.4	
RWK 305-143-KS	143	75	0.041	115		KS		10.7	2.7	
RWK 305-156-KS	156	75	0.038	120		KS		10.7	2.85	
RWK 305-170-KS	170	90	0.035	130		KS		10.7	3.8	
RWK 305-182-KS	182	90	0.032	140		KS		16	2.8	
RWK 305-230-KS	230	132	0.026	180		KS		22	3.5	
RWK 305-280-KS	280	160	0.021	220		KS		29	2.8	
RWK 305-330-KS	330	160	0.018	240		KS		32	3.5	
RWK 305-400-S	400	200	0.015	330			S	34	3.8	2
RWK 305-500-S	500	250	0.012	340			S	35	5.4	3.3
RWK 305-600-S	600	355	0.01	380			S	37	5.4	3.3
RWK 305-680-S	680	400	0.009	410			S	38	7.2	3.5
RWK 305-790-S	790	450	0.007	590			S	43	10.5	3.5
RWK 305-910-S	910	500	0.006	740			S	49	12	3
RWK 305-1100-S	1100	630	0.005	760			S	66	12	3.5
RWK 305-1500-S	1500	750	0.004	1045			S	97	20.3	4.7
RWK 305-1920-S	1920	1100	0.003	1090			S	105	26	7.7
RWK 305-2300-S	2300	1320	0.002	1160			S	108	38	8.5

* General purpose 4-pole (1500r/min) AC induction motor rated 400V/50Hz.

** Exact value depends upon the motor cable type and length, switching frequency, motor frequency and further stray parameters within the system.

Reactor derating

The maximum admissible motor cable length depends mainly on the switching frequency and the drive output voltage. The applicable value for a given application can be found in the derating curve below.

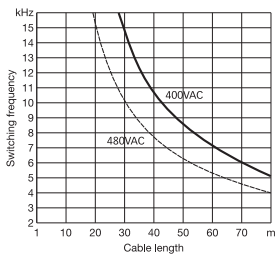

Mechanical data

2.1 to 60A types

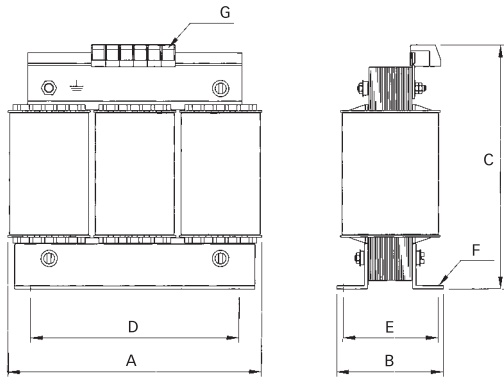

72 to 110A types

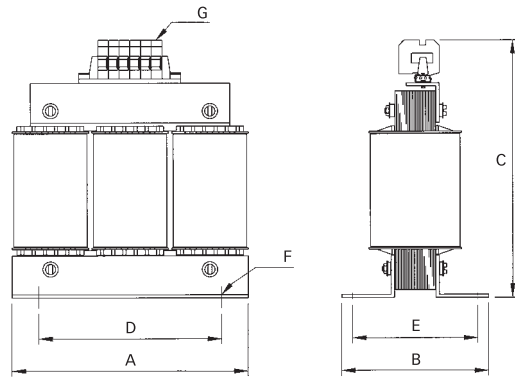

124 to 330A types

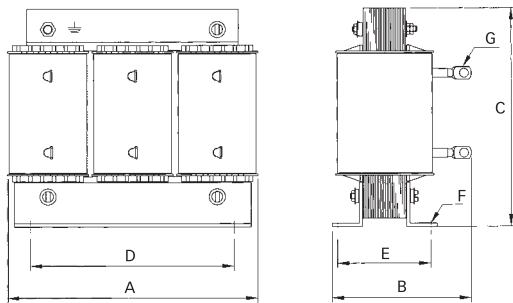

400 to 2300A types

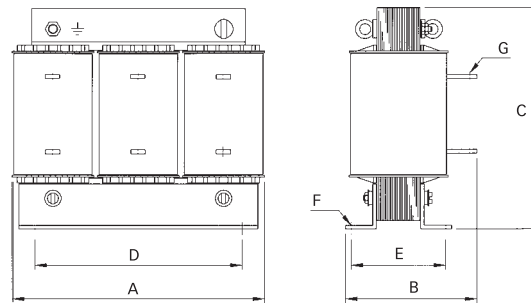

Dimensions

	A	B	C	D	E	F	G
2.1 to 7.8A	100	57	120	56	34	4.8 x 8	1.5mm ²
10A	100	65	120	56	43	4.8 x 8	2.5mm ²
14A	125	70	140	100	45	5 x 8	2.5mm ²
17A	125	80	140	100	55	5 x 8	2.5mm ²
24A	125	80	140	100	55	5 x 8	4mm ²
32A	155	95	195	130	56	8 x 12	10mm ²
45 to 60A	155	110	195	130	70	8 x 12	10mm ²
72A	155	110	205	130	70	8 x 12	16mm ²
90A	190	100	240	130	57	8 x 12	35mm ²
110A	190	110	240	130	67	8 x 12	35mm ²
124A	190	150	170	130	67	8 x 12	Ø8
143A	190	160	170	130	77	8 x 12	Ø8
156 to 170A	190	160	170	130	77	8 x 12	Ø10
182A	210	160	185	175	95	8 x 12	Ø10
230A	240	220	220	190	119	11 x 15	Ø12
280A	240	235	220	190	133	11 x 15	Ø12
330A	240	240	220	190	135	11 x 15	Ø12
400 to 500A	240	220	325	190	119	11 x 15	Ø11
600 to 680A	240	230	325	190	128	11 x 15	Ø11
790A	300	218	355	240	136	11 x 15	Ø11
910A	300	228	355	240	148	11 x 15	Ø11
1100A	360	250	380	310	144	11 x 15	Ø11
1500 to 1920A	360	265	485	310	159	11 x 15	Ø11
2300A	360	260	595	310	144	11 x 15	Ø11

All dimensions in mm; 1 inch = 25.4mm

Tolerances according: ISO2768 / EN22768