

LC sine wave filter for motor drives



- Smooth sine wave without voltage peaks
- Motor protection against pulse pattern stress
- Improvement of system reliability
- Simple to install

Approvals



Technical specifications

Nominal operating voltage:	3x 500VAC ±10%
Motor frequency:	0 to 70Hz (up to 200Hz with derating (see graph))
Switching frequency:	See filter selection table
Rated currents:	4.5 to 1200A @ 45°C
Motor cable length:	Up to 2,000m (see graph)
Impedance (uk):	8 to 10% @ 400V, 50Hz and rated current
Residual ripple voltage:	<5%
High potential test voltage:	P → E 3000VAC, 1 minute P → P 2500VAC, 1 minute
Protection category:	IP00 (FN 5040) IP20 (FN 5045)
Overload capability:	1.5x rated current for 1 minute, once per hour
Temperature range (operation and storage):	-25°C to +70°C (25/070/21)
Acoustic noise level:	<70dB(A) @ 1m
Insulation class:	EIS 200
Flammability corresponding to:	UL 94V-2 or better
Design corresponding to:	IEC 61558-2-20
Environmental reliability:	IEC 60068-2-1
MTBF:	>100,000 hours
Approvals:	UL 508 pending
Declaration of conformity:	CE / LVD

Typical electrical schematic

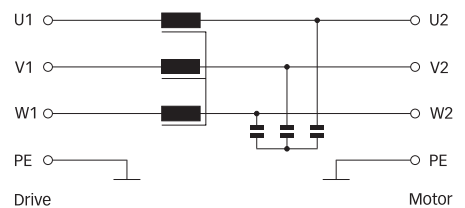

Features and benefits

- Converts the rectangular PWM output voltage of motor drives into a smooth sine wave with low residual ripple.
- Elimination of premature motor damage caused by high dv/dt, overvoltages, cable ringing, motor overheating, and eddy current losses.
- Improves bearing life time because of bearing currents caused by circulating currents.
- Complies with IEC 60054-17* and NEMA-MG1 requirements for general purpose motors.
- Optional with NEMA 1 protective cover.

Typical applications

- HVAC applications
- Pumps
- Ventilators
- Conveyors
- Compressors
- Elevators
- Cranes
- Medium voltage applications, deployed in front of the step-up transformer
- Retrofit installations with motor drives
- Motor drive with long motor cable
- Motor drive with multiple motors in parallel

Filter selection table

Filter	Rated current @ 45°C/50Hz	Rated current @ 45°C/100Hz	Typical motor drive rating	Nominal inductance	Nominal capacitance	Capacitance connection	Min. switching frequency	Typical power loss	Input/Output connections 	Weight [kg]
	[A]	[A]	[kW]	[mH]	[µF]		[kHz]	[W]		
FN 5040-4.5-82	4.5	4.05	1.1/1.5	13	2.2	Y	4	65	-82	3.3
FN 5040-8-82	8	7.2	2.2/3	6.9	4.7	Y	4	80	-82	4.6
FN 5040-10-83	10	9	4	5.2	6.8	Y	4	90	-83	6.1
FN 5040-17-83	17	15.3	5.5/7.5	3.1	10	Y	4	115	-83	7.8
FN 5040-24-84	24	21.6	11	2.4	10	Y	4	150	-84	14.4
FN 5040-38-84	38	34.2	15/18.5	1.6	10	Y	4	170	-84	17.7
FN 5040-48-85	48	43.2	22	1.1	14.7	Y	4	260	-85	34.0
FN 5040-62-85	62	55.8	30	0.85	30	Y	3	280	-85	36.0
FN 5040-75-87	75	67.5	37	0.75	30	Y	3	330	-87	42.0
FN 5040-115-87	115	103.5	45/55	0.5	20	Δ	3	500	-87	68.0
FN 5040-180-99	180	162	75/90	0.3	33	Δ	3	680	-99	86.0
FN 5040-260-99	260	234	110/132	0.2	47	Δ	3	880	-99	125.0
FN 5040-410-99	410	369	160/200	0.13	66	Δ	3	1100	-99	190.0
FN 5040-480-99	480	432	250	0.11	94	Δ	3	1350	-99	235.0
FN 5040-660-99	660	594	315/355	0.14	141	Δ	2	2000	-99	310.0
FN 5040-750-99	750	675	400	0.12	165	Δ	2	2800	-99	470.0
FN 5040-880-99	880	792	450/500	0.11	188	Δ	2	3400	-99	640.0
FN 5040-1200-99	1200	1080	560/630	0.075	282	Δ	2	3800	-99	680.0
FN 5045-4.5-44	4.5	4.05	1.1/1.5	13	2.2	Y	4	65	-44	4.1
FN 5045-8-44	8	7.2	2.2/3	6.9	4.7	Y	4	80	-44	5.4
FN 5045-10-44	10	9	4	5.2	6.8	Y	4	90	-44	6.9
FN 5045-17-33	17	15.3	5.5/7.5	3.1	10	Y	4	115	-33	9.0
FN 5045-24-33	24	21.6	11	2.4	10	Y	4	150	-33	15.6
FN 5045-38-33	38	34.2	15/18.5	1.6	10	Y	4	170	-33	18.9
FN 5045-48-34	48	43.2	22	1.1	14.7	Y	4	260	-34	35.8
FN 5045-62-34	62	55.8	30	0.85	30	Y	3	280	-34	37.8
FN 5045-75-35	75	67.5	37	0.75	30	Y	3	330	-35	44.0
FN 5045-115-35	115	103.5	45/55	0.5	20	Δ	3	500	-35	70.0
FN 5045-180-99	180	162	75/90	0.3	33	Δ	3	680	-99	92.0
FN 5045-260-99	260	234	110/132	0.2	47	Δ	3	880	-99	131.0
FN 5045-410-99	410	369	160/200	0.13	66	Δ	3	1100	-99	198.0
FN 5045-480-99	480	432	250	0.11	94	Δ	3	1350	-99	243.0
FN 5045-660-99	660	594	315/355	0.14	141	Δ	2	2000	-99	322.0
FN 5045-750-99	750	675	400	0.12	165	Δ	2	2800	-99	482.0
FN 5045-880-99	880	792	450/500	0.11	188	Δ	2	3400	-99	652.0
FN 5045-1200-99	1200	1080	560/630	0.075	282	Δ	2	3800	-99	692.0

Installation

■ **Filter placement**

Lift the filter with appropriate crane using lifting eye bolts – smaller types may be lifted manually by two persons (no lifting eye bolt applicable).

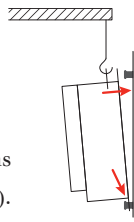

Never attempt to handle the filter with a forklift!

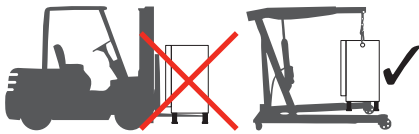

In order to ensure sufficient air flow, keep a distance of 150mm above and below the filter to walls or other components. A 20mm distance on either side is recommended.

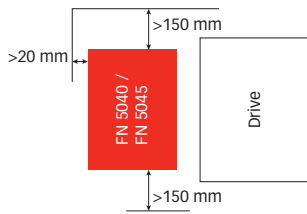

■ **Wiring and connections**

The filter rating has to be compatible with the inverter to which it is to be connected. All inverter manufacturer installation and safety instructions must be fulfilled. The typical block schematic is shown for a motor load but the load can be also multiple motors or a transformer. Inverter and load cable selection/ placement should be in accordance with all local electrical standards and regulations. Filters with separate capacitor bank must be connected as follows:

Var. 1 (180, 260, 410, 480, 660 and 880A)

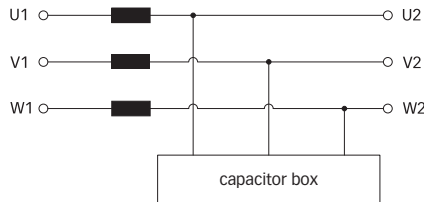

Variante 2 (750 and 1200A)

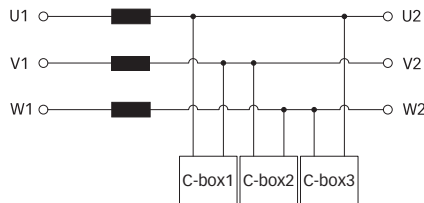

■ **Required settings**

Ensure the drive's switching frequency is set to the required minimum switching frequency (see filter selection table). Higher frequencies are allowed. The mode of operation must be "scalar" (V/Hz). Check the inverter manual whether special settings are necessary. In any doubt contact the inverter manufacturer.

CAUTION: If the inverter settings are not in accordance the filter may be damaged.

Typical block schematic

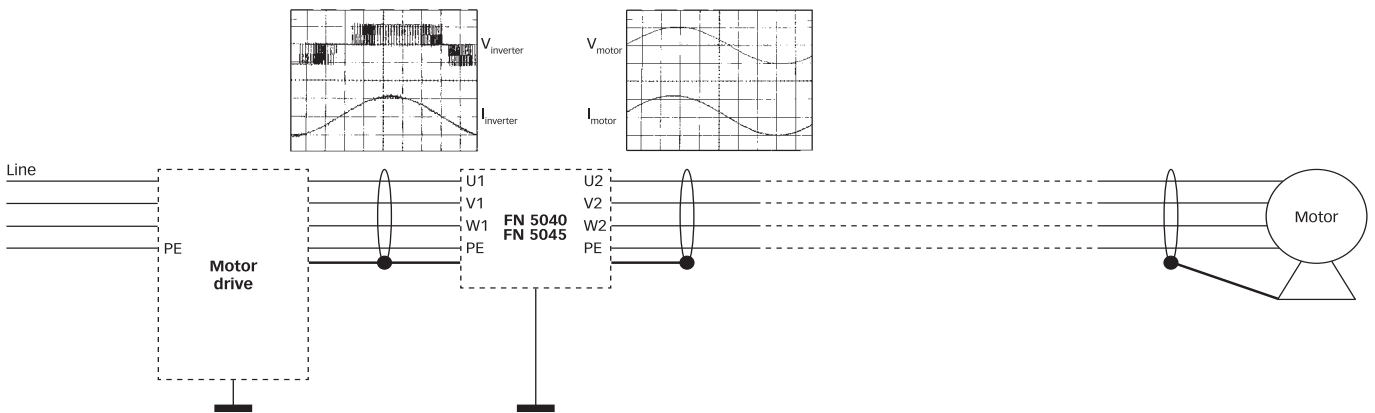

Motor frequency derating

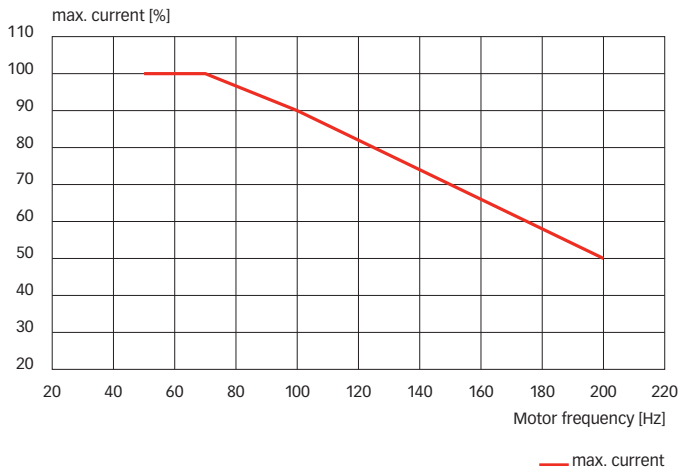

Max. motor cable length

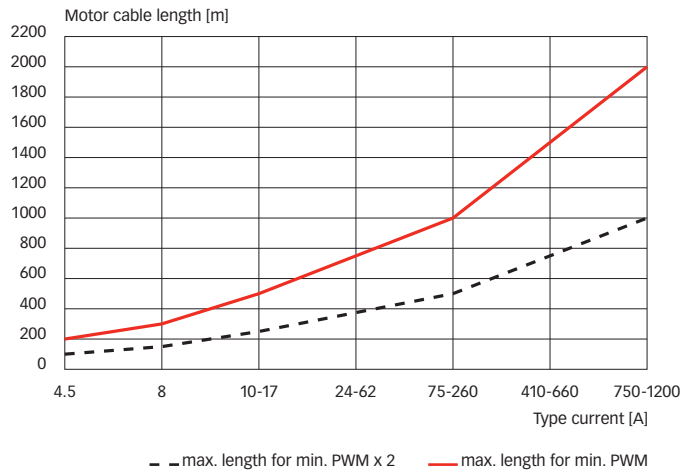

Mechanical data FN 5040

4.5 to 75A types

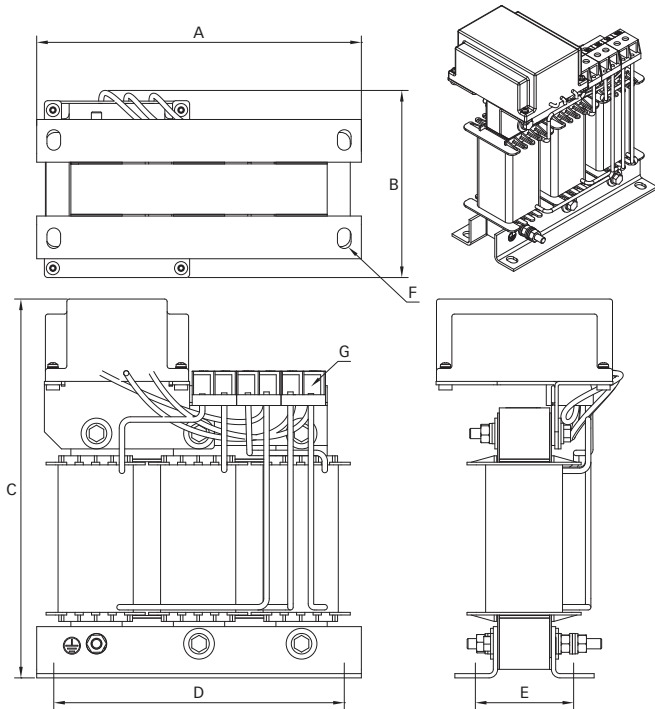

115A types

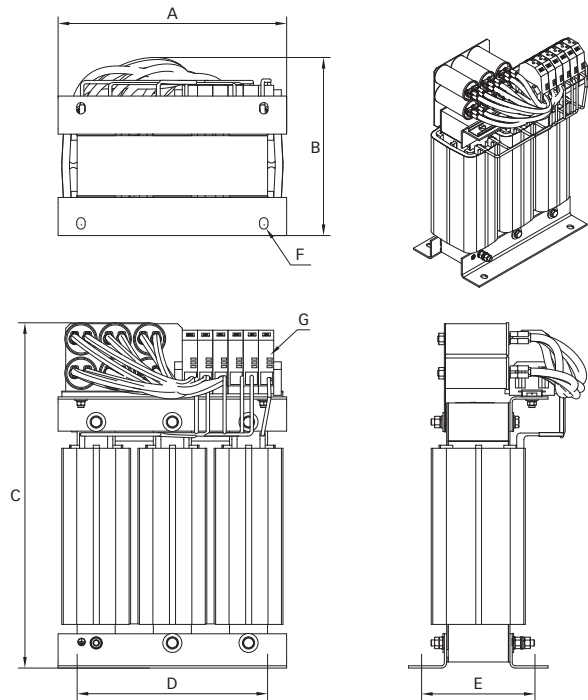

180 to 1200A types*

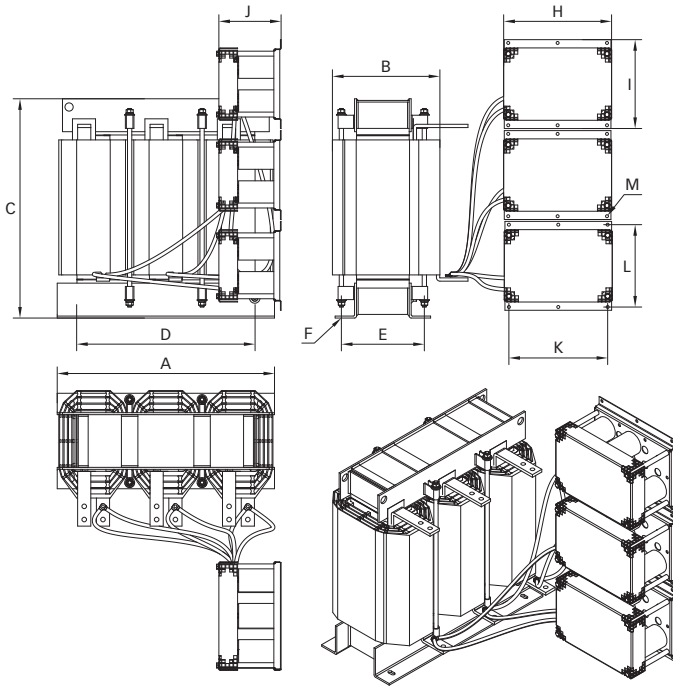

* Filters from 180 to 660A have only 1 capacitor module

Dimensions FN 5040

	4.5A	8A	10A	17A	24A	38A	48A	62A	75A	115A
A	126	155	155	190	190	230	300	300	300	300
B	77	84	94	115	116	151	171	186	240	236
C	171	212	208	224	224	264	344	373	373	257
D	100	130	130	170	170	180	240	240	240	240
E	55	57	71.5	55.5	77.5	122	137		162	152
F	5x8	8x12	8x12	8x12	8x12	8x12	11x15	11x15	11x15	11x15
G	2.5mm ²	2.5mm ²	4mm ²	4mm ²	10mm ²	10mm ²	16mm ²	35mm ²	50mm ²	50mm ²

	180A	260A	410A	480A	660A	750A	880A	1200A
A	450	450	480	510	630	660	882	740
B	240	240	240	310	315	365	370	360
C	385	450	596	614	727	666	882	913
D	400	370	430	430	570	570	570	570
E	130	150	190	130	210	220	220	220
F	9x13	10x15	9x13	13x27	13x26	13x26	13x26	13x26
H	328	328	328	328	436	328	436	328
I	170	170	270	270	370	270	370	270
J	172	187	176	191	229	196	229	191
K	300 (150)	300 (150)	300 (150)	300 (150)	400 (200)	300 (150)	400 (200)	300 (150)
L	150	150	250	250	350	250	350	250
M	M10	M10	M10	M10	M12	M12	M10	M12
V	30	30	40	40	40	40	50	60
W	5	6	6	6	10	10	10	10
X	13/15	13/15	13/16	13/20	20	20	14	17
Z	10.3	10.3	10.3	10.3	14	14	11	14

All dimensions in mm; 1 inch = 25.4mm
Tolerances according: ISO 2768-m / EN 22768-m

Mechanical data FN 5045

4.5 to 38A types

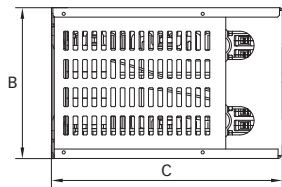
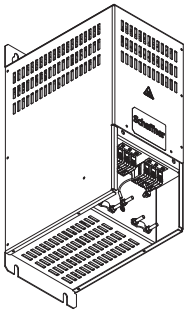
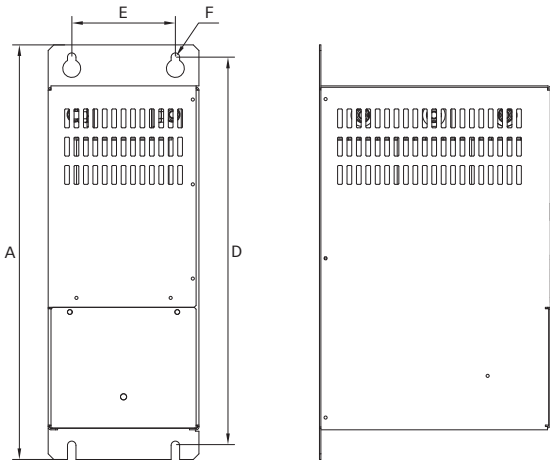

48 to 115A types

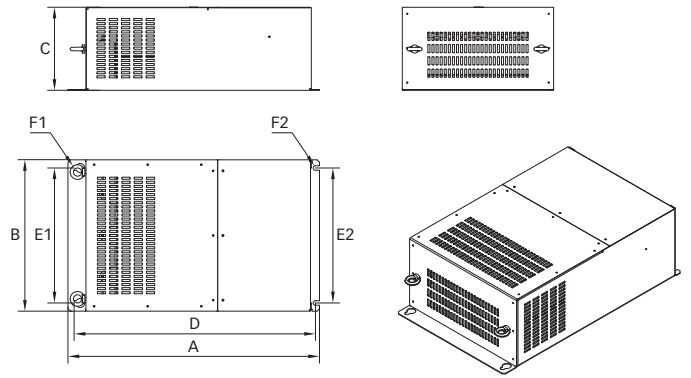

180 to 480A types

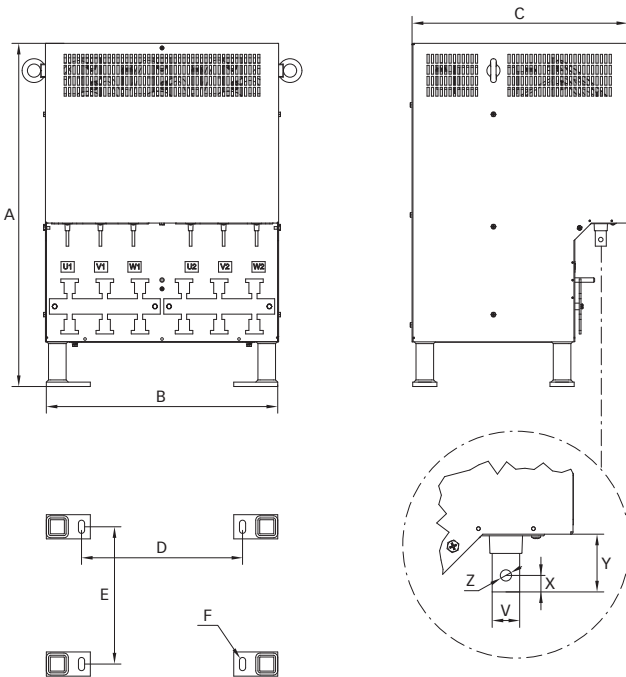

660 to 1200A types

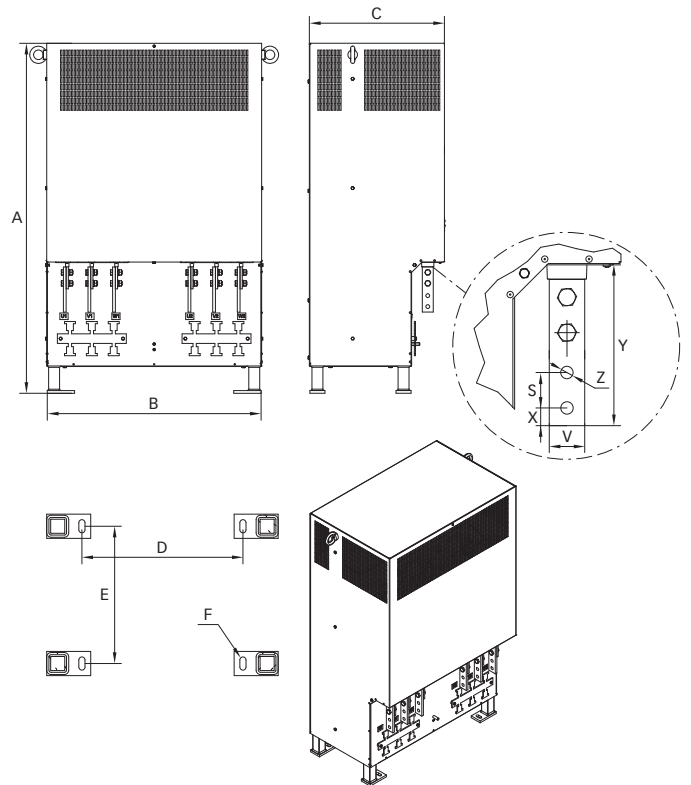





Dimensions FN 5045

	4.5A	8A	10A	17A	24A	38A	48A	62A	75A	115A	180A	260A	410A	480A	660A	750A	880A	1200A
A	330	330	330	440	440	440	515	515	615	615	650	650	780	780	1280	1280	1280	1280
B	100	100	100	160	160	160	310	310	370	370	500	500	534	534	794	794	794	794
C	165	165	165	245	245	245	153	153	203	203	400	400	500	500	498	498	498	498
E	310	310	310	400	400	400	475	475	575	575	243	243	322	322	315	315	315	315
F	60	60	60	110	110	110	270	270	330	330	336	336	366	366	622	622	622	622
G	7	7	7	9	9	9	9	9	11	11	14x30	14x30	14x30	14x30	14x30	14x30	14x30	14x30
J	M5	M5	M5	M5	M5	M5	M6	M6	M8	M8	M10	M10	M10	M10	M10	M10	M10	M10
V											20	20	25	25	40	40	40	40
W											5	5	6	6	8	8	8	8
X											15	15	15	15	20	20	20	20
Y											35	35	55	55	70	70	70	70
Z											10	10	10	10	10	10	10	10

All dimensions in mm; 1 inch = 25.4mm
Tolerances according: ISO 2768-m / EN 22768-m

Filter output connector cross sections

	-82	-83	-84	-85	-87
					
Solid wire	0.75 - 2.5mm ²	0.75 - 4.0mm ²	2.5 - 10.0mm ²	2.5 - 25.0mm ²	16.0 - 50.0mm ²
Flex wire	1.0 - 2.5mm ²	1.0 - 4.0mm ²	4.0 - 10.0mm ²	4.0 - 16.0mm ²	25.0 - 50.0mm ²
AWG type wire	AWG 18 - 12	AWG 18 - 10	AWG 18 - 6	AWG 22 - 4	AWG 6 - 0
Recommended torque	1.0 - 1.2Nm	1.5 - 1.8Nm	4.0 - 4.5Nm	1.5 - 1.8Nm	6.0 - 8.0Nm

Please visit www.schaffner.com to find more details on filter connectors.